

FRONT VIEW

SIDE VIEW

TABLE "A" RAFTER SPANS (DOUGLAS FIR #2 OR BETTER)			TABLE "B" HEADER SIZE & SPANS (DOUGLAS FIR #2 OR BETTER)			TABLE "C" FOOTING SIZE		TABLE "D" LEDGER BOLTING Δ	
SIZE	SPACING	SPAN	RAFTER SPAN	HEADER		BASED ON 1000 P.S.F. SOIL BEARING PRESSURE.		ALL LAG BOLTS SHALL HAVE 1/4" PRE-DRILLED HOLES - (SEE NOTE 2)	
				SPAN	SIZE				
2 x 4	12" O.C.	9' - 10"	UP TO 12'-0"	8'-0" MAX	4 x 6	18" SQ. X 12" DEEP	18" SQ. X 12" DEEP	1/2" DIA. X 5" LONG AT 16" O.C. STAGGERED	
	16" O.C.	8' - 11"		10'-0" MAX	4 x 8	18" SQ. X 12" DEEP			
	24" O.C.	7' - 8"		12'-0" MAX	4 x 10	18" SQ. X 12" DEEP			
	32" O.C.	*6' - 3"		14'-0" MAX	4 x 12	18" SQ. X 12" DEEP			
2 x 6	12" O.C.	15' - 4"	12'-1" TO 20'-0"	8'-0" MAX	4 x 8	24" SQ. X 12" DEEP	24" SQ. X 12" DEEP	(2) 3/8" DIA X 5" LONG AT 16" O.C.	
	16" O.C.	13' - 9"		10'-0" MAX	4 x 10	24" SQ. X 12" DEEP			
	24" O.C.	11' - 3"		12'-0" MAX	4 x 12	24" SQ. X 12" DEEP			
	32" O.C.	*9' - 7"		14'-0" MAX	4 x 14	24" SQ. X 12" DEEP			
2 x 8	12" O.C.	20' - 0"	NOTES: 1. TWO 2X MEMBERS MAY BE SUBSTITUTED FOR ONE 4X HORIZONTAL FRAMING MEMBER. 2. LAG BOLTS MUST FULLY ENGAGE A WOOD STUD OR RIM JOIST AND BE PROVIDED WITH APPROPRIATE WASHERS. LAG BOLTS SHALL BE LOCATED A MINIMUM OF 1-1/2" FROM THE TOP OR BOTTOM OF THE LEDGER. 3. NOT DESIGNED TO BE ENCLOSED - ADDITIONAL ENGINEERING ANALYSIS WILL BE REQUIRED IF ENCLOSED. 4. SEE PAGE 2 OF 2 FOR CONSTRUCTION DETAILS. 5. ARTIFICIAL LIGHTING IS REQUIRED IN ROOMS THAT HAVE WINDOW OPENINGS INTO THE COVERED PATIO AREA IF THE TOTAL WINDOW AREA IN THAT ROOM IS LESS THAN 10% OR THE FLOOR AREA OF THE ROOM OR 20 SQUARE FEET, WHICHEVER IS GREATER. Δ						
	16" O.C.	18' - 2"							
	24" O.C.	14' - 10"							
	32" O.C.	*12' - 8"							
2 x 10	12" O.C.	20' - 0"							
	16" O.C.	20' - 0"							
	24" O.C.	18' - 11"							
	32" O.C.	*16' - 2"							
4 x 4	24" O.C.	10' - 0"							
	32" O.C.	*9' - 3"							
	48" O.C.	*7' - 8"							
4 x 6	24" O.C.	15' - 11"							
	32" O.C.	*13' - 9"							
	48" O.C.	*11' - 3"							
4 x 8	24" O.C.	20' - 0"							
	32" O.C.	*18' - 2"							
	48" O.C.	*14' - 10"							

* THIS SPACING AND SPAN IS FOR LATTICE PATIO COVERINGS ONLY.

Any Gas lines under the patio cover must be sleeved and vented. 2022 CPC 1210.1.6 Gas and Plumbing require a separate permit

WESTERN RIVERSIDE COUNTY CODE UNIFORMITY PROGRAM			
		CITY OF MURRIETA	
		BUILDING DEPARTMENT	
PATIO COVER STANDARD			
TEL 951.304.CITY		1 TOWN SQUARE MURRIETA, CA 92562	
FAX 951.461.6097		8/27/2009 Δ	PATIOStd2008.VSD
		PAGE 1 OF 2	

KNEE BRACE DETAIL AT END POSTS

(REQUIRED WHEN RAFTER SPAN EXCEEDS 12 FT.)

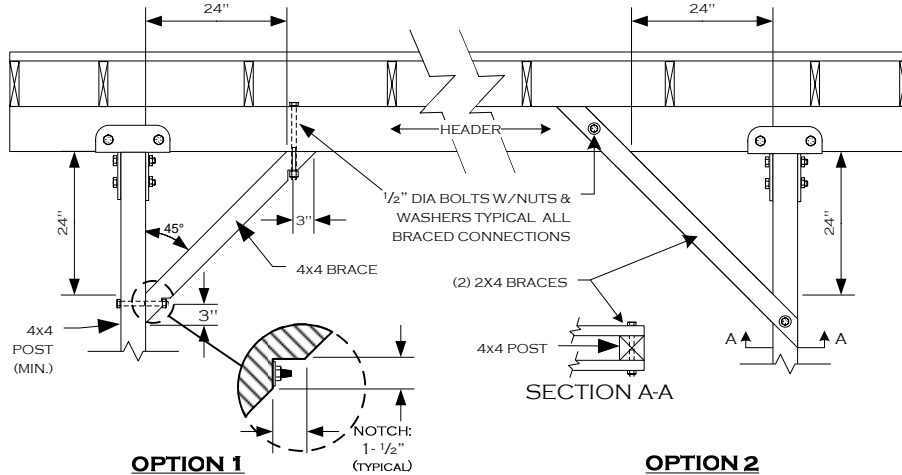

LEDGER ATTACHMENT

DETAIL

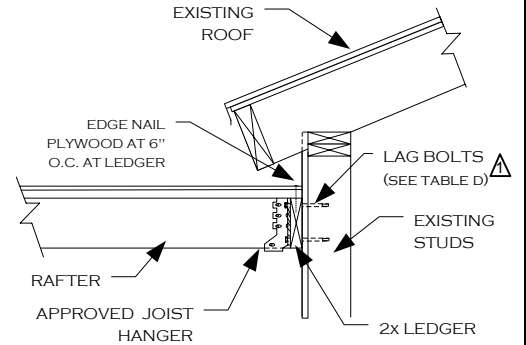

NOTES:

1. USE A CONTINUOUS 2X LEDGER – SAME DEPTH AS RAFTER OR LARGER
2. SEE TABLE "D" FOR BOLTING REQUIREMENTS

INVERTED HEADER DESIGN OPTION (LATTICE ONLY)

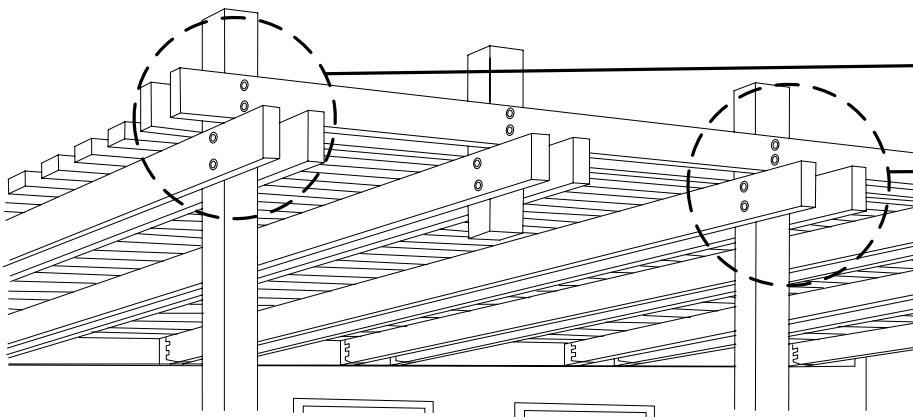

NOTE: KNEE BRACING REQUIRED WHEN RAFTER SPAN EXCEEDS 12 FEET

2X FASCIA (OVERHANG) ATTACHMENT – LATTICE ONLY

OPTION 1

OPTION 2

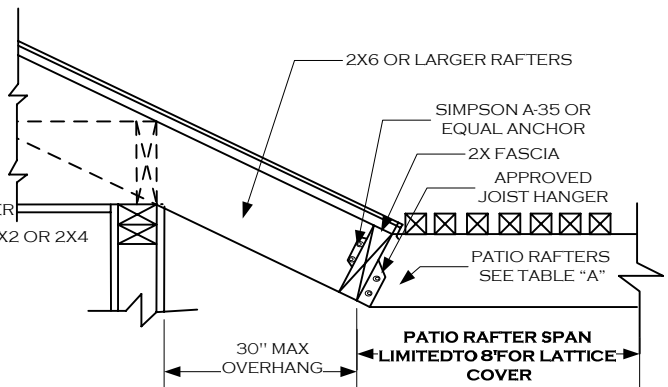
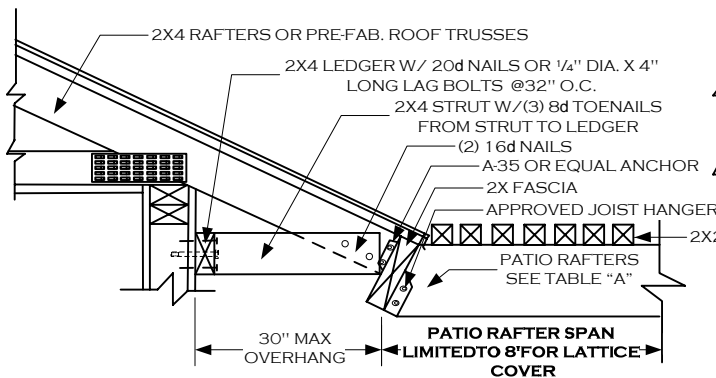

Any Gas lines under the patio cover must be sleeved and vented. 2022 CPC 1210.1.6 Gas and Plumbing require a separate permit

NOTE: VERIFY STRUCTURAL SOUNDNESS OF ROOF RAFTERS FOR DECAY OR TERMITE DAMAGE, AND REPLACE WITH LIKE MATERIALS AS NEEDED, AFTER CONSULTATION WITH THE BUILDING DEPARTMENT.

WESTERN RIVERSIDE COUNTY CODE UNIFORMITY PROGRAM



CITY OF MURRIETA BUILDING DEPARTMENT

PATIO COVER STANDARD

TEL 951.304.CITY

FAX 951.461.6097

1 TOWN SQUARE
MURRIETA, CA 92562

8/27/2009

PATIOStd2008.VSD

PAGE 2 OF 2